

emco group

Designed for your profit



Your profit

EMCOTURN E45

**CNC turning center for bar stock work
up to Ø 45 (51) mm and chucking work**

TURNING
EMCO-WORLD.COM

The EMCOTURN E45 i

1 WORK AREA

- Plenty of open space
- Straight chip fall
- Top ergonomics

2 TOOL TURRET

- 12 stations VDI 30 axial
- 6 stations driven
- Tapping without length compensation
- Polygonal turning, mesh, etc.

3 SPINDLE

- High drive performance
- Thermoresistant construction
- Large speed range
- A2-5 spindle connection
- Bar capacity Ø 45 (51) mm

4 BAR LOADER PACKAGE

- Short bar loader
- Max. bar length 1100 mm
- Incl. spindle extension
- Parts catcher
- Interface
- Warning light
- Adaptor sleeves



Threaded bolt
(Heat treatable steel)



Fitting
(Steel)

n the tailstock version

Perfect European engineering, superbly equipped with a Y axis, 200 mm more machining length, C axis, driven tools with a 4 kW drive performance and a choice of a Siemens or Fanuc control unit. A cost-effective bar loader package or an integrated automation solution is available on request.



5 CONTROL UNIT

- Cutting-edge digital control technology
- Sinumerik 828D / 10,4" or Fanuc 0i-TF / 15" incl. ShopTurn or ManuaGuide i

6 SHELF

- Space for measuring devices and operatin tools
- Optional for the Sinumerik PC keyboard

7 Y-AXIS

- Travel +40 / -30 mm
- 90° implemented in the machine construction
- Large distance between guide rails
- Stable and compact construction, without restrictions

8 MACHINE CLADDING

- Comprehensive protection against chip flying
- 100% coolant-tight
- Large door safety glass
- Free view into the workroom
- Built-in buttons make it easier to operate the machine
- Easy to clean the coolant tank

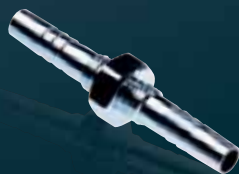

Socket
(Stainless steel)



Pin guide
(Heat treatable steel)

The EMCOTURN E45 in the

1 WORK AREA

- Plenty of open space
- Straight chip fall
- Top ergonomics

2 TOOL TURRET

- 12 stations VDI 25 radial
- 12 stations driven
- Servo controlled with adjustable swivel speed
- Tapping without length compensation
- Polygonal turning, mesh, etc.

3 SPINDLE

- High drive performance
- Thermoresistant construction
- Large speed range
- A2-5 spindle connection
- Bar capacity \varnothing 45 (51) mm

4 COUNTER SPINDLE

- Complete machining of components
- Incl. C axis for milling operations
- Incl. part ejector
- Incl. flushing
- Optionally available with a passage for unloading long shaft parts

5 HYDRAULIC PRESSURE ADJUSTMENT

- Ergonomically designed
- Automatic alignment of the pressure switch

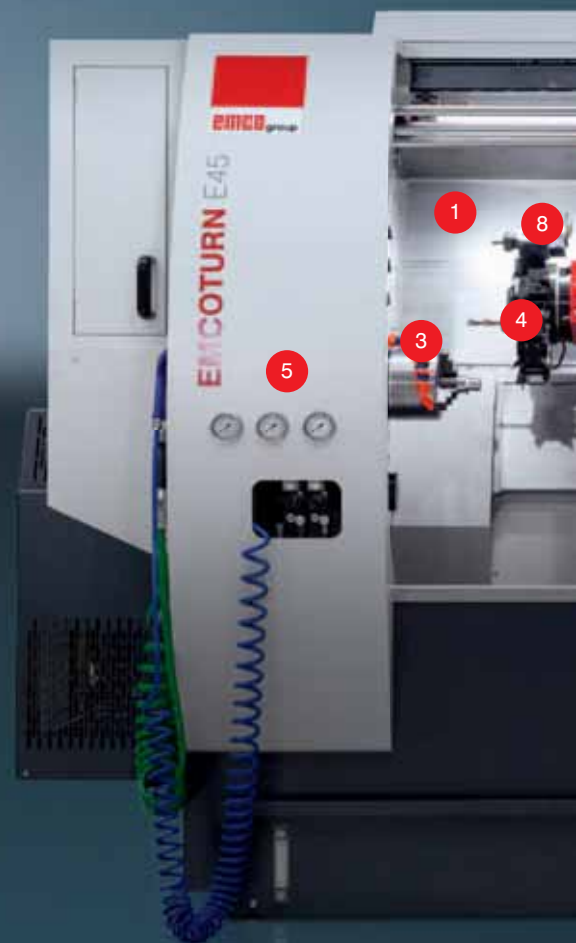

Distributor
(Brass)



Camshaft
(Brass)

counter spindle version

The EMCOTURN E45 SMY. The perfect solution for economic, off-the-shelf complete machining. Fitted with a counter spindle, driven tools, a high-precision C axis and extremely fast rapid motion speeds, the EMCOTURN E45 SMY gives you everything you need for manufacturing complex turned-milled parts efficiently and at a low price. The highlight of the machine is its very stiff Y axis with long travel – for almost unlimited machining capabilities with maximum precision.

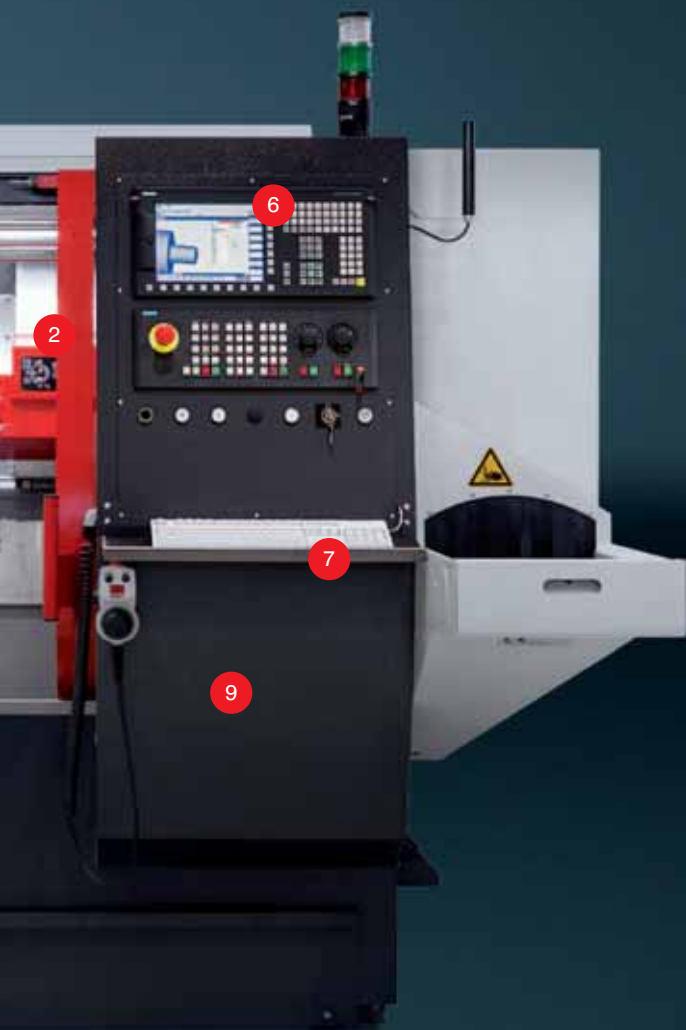

6 CONTROL UNIT

- Cutting-edge digital control technology
- Siemens 828D / 10,4" or Fanuc 0i-TF / 15" incl. ShopTurn or ManualGuide i

7 SHELF

- Space for measuring devices and operating tools
- Optional for the Sinumerik PC keyboard

8 Y-AXIS

- Travel +40 / -30 mm
- 90° implemented in the machine construction
- Large distance between guide rails
- Stable and compact construction, without restrictions

9 MACHINE CLADDING

- Comprehensive protection against chip flying
- 100% coolant-tight
- Large door safety glass
- Free view into the workroom
- Built-in buttons make this easier to operate the machine
- Easy to clean the coolant tank



Eccentric disc
(Aluminium)



Push-on contact
(Steel)



Tooling system. 12-station axial style tool turret VDI30 with two bolt hole circles. The outer for the stationary tools, the inner one for up to 6 driven tool. No tool rise, interconnection with directional logic. Switches with bidirectional logic DIN 5480 coupling.

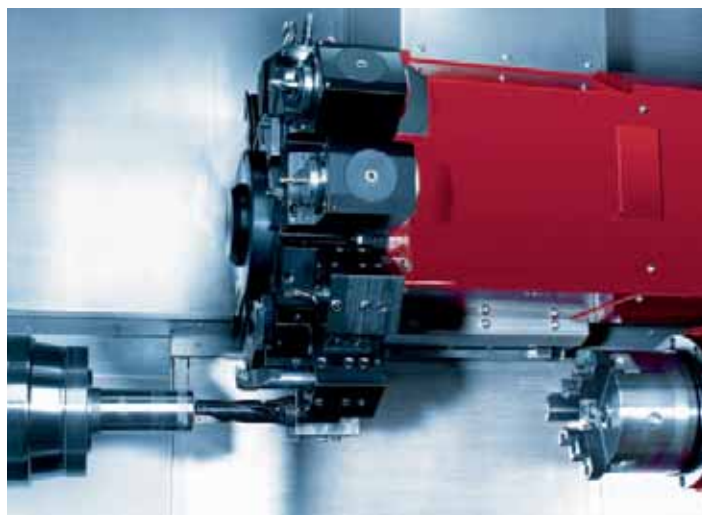

Tool head. 12-position VDI 25 radial turret with single-motor engineering. A servo motor powers the driven tools and the swivel movement. No tool rise. Switches with bidirectional logic. Every station can hold driven tool holders with a DIN 5480 coupling.

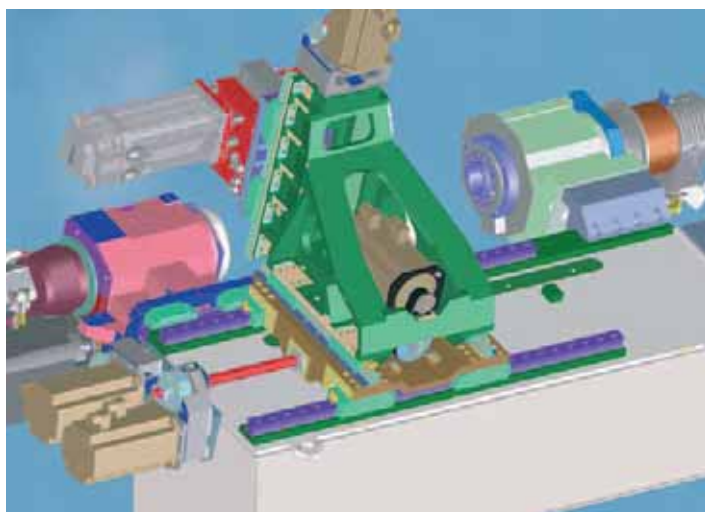

Y axis. The Y axis is integrated into the basic machine structure and stands at 90° to the X axis. Extremely short projections form the basis for solid turning and drilling operations, as well as milling operations without interference contours.

EMCOTURN E45 Technical

1 MAIN SPINDLE

- High drive power
- Compact, thermostable construction
- Large speed range
- A 2-5 spindle nose
- Bar capacity diameter 45 mm (51 1.8"(2.0"))

2 MACHINE BASE

- Extremely stiff welded steel fabrication
- Compact structure
- Very high thermostability
- Filled with vibration-absorbing material

3 ROLLER GUIDES

- In all linear axes
- Preloaded
- No backlash in any direction of force
- High rapid motion speeds
- No wear
- Minimal lubrication

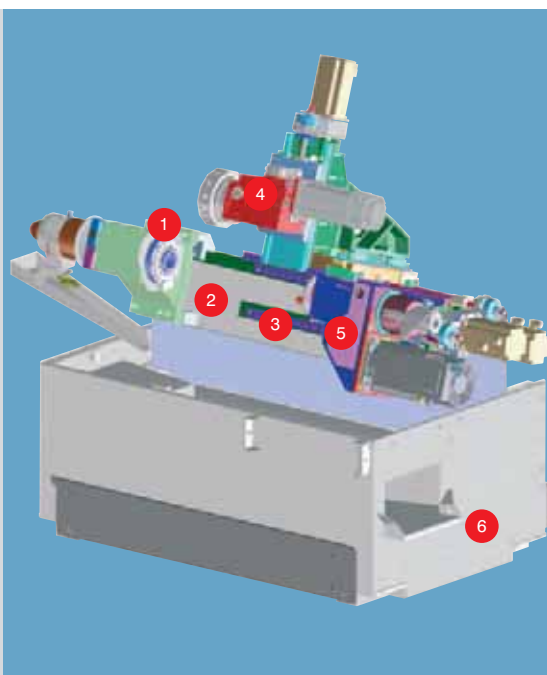

4 TOOL TURRET

- VDI quick change system
- 12 driven tool stations
- No alignment of the tool holder
- Can be used on both spindles
- Swivel speed adjustable with override

5 COUNTER SPINDLE

- Large speed range
- C axis
- Spindle clamp
- A 2-4 spindle nose

6 MACHINE STAND

- Thermally isolated from the machine base
- Coolant container that is larger and easier to clean
- 100% sealed against coolant leaks



Counter spindle and parts catcher. The counter spindle includes a parts ejector with stroke monitoring and coolant feed. It ejects the parts automatically into the parts catcher, which then removes them from the machine and stores them in a bin or on an accumulating conveyor.

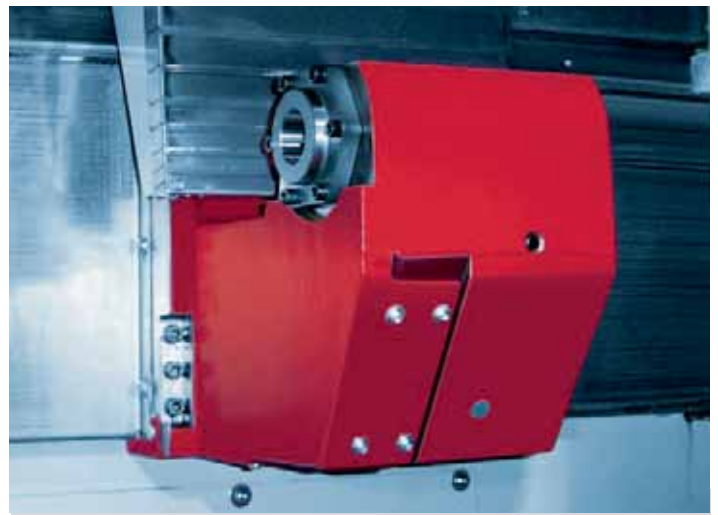

Tailstock. On the EMCOTURN E45 with tailstock, the tailstock is set up on the linear roller slide and can be automatically positioned within a range of 510 mm. The live center is integrated into the body of the tailstock and can be removed using a pressure wedge.

Highlights

Highlights

- Powerfull driven tools
- Y axis for complexe milling operations
- Counter spindle for complete machining
- 200 mm more working length for shafts
- Flexible automatic tailstock
- Top thermostability
- Extreme machining precision
- Very compact machine layout
- State-of-the-art control technology from Siemens or Fanuc incl. ShopTurn or ManualGuide i
- Made in the Heart of Europe

Validated quality

ROUNDNESS AND SURFACE QUALITY

Material: Brass	(Cu Zn 40 Pb 2)
Cutting tool:	Carbide insert CCGX 09 T3 04-AL
Turning diameter:	ø 45 mm
Cutting speed:	300 m/min
Feed rate:	0.025 mm/rev
Cutting depth:	0.03 mm

As measured:	
Roundness:	0.45 μm
Surface finish:	Ra = 0.163 μm

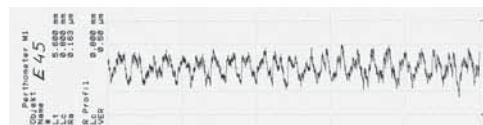

REPEAT ACCURACY

Material:	Steel - 16 Mn Cr 5
Turning diameter:	ø 45 h6
Tolerance:	16 μm
Spindle speed:	2000 rpm
Feed rate:	0.08 mm/rev
Cutting depth:	0.2 mm

As measured:	
Range:	4 μm
Cm value:	2.57



Long term machining accuracy: 4 μm

Work area EMCOTURN E45 with tailstock

Work area and turret clearance EMCOTURN E45

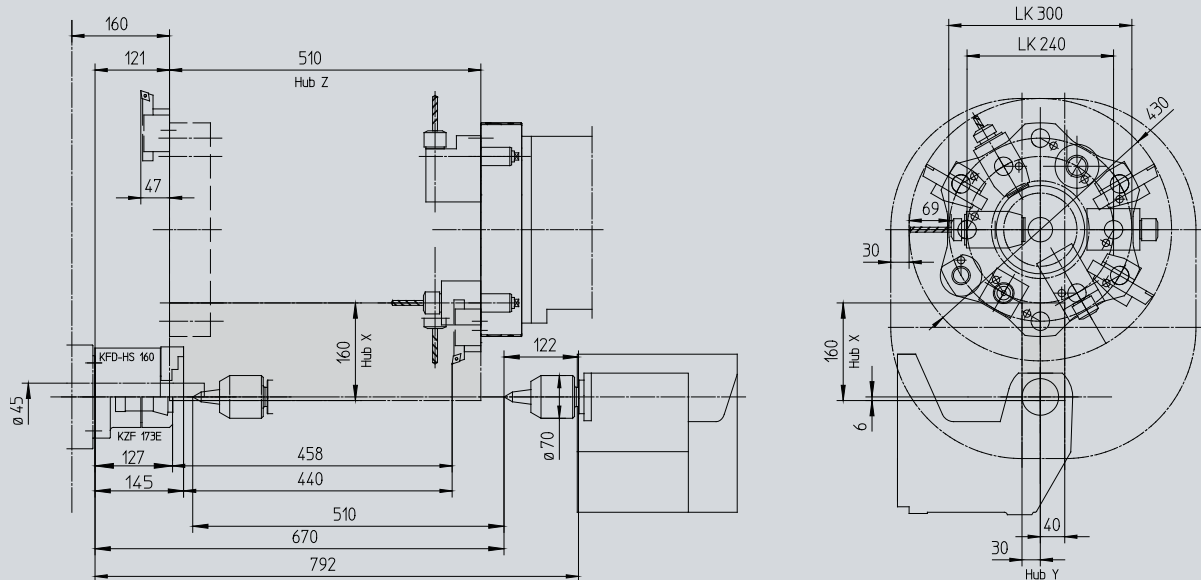

Machine layout

EMCOTURN E45 with EMCO COMPACT LOAD

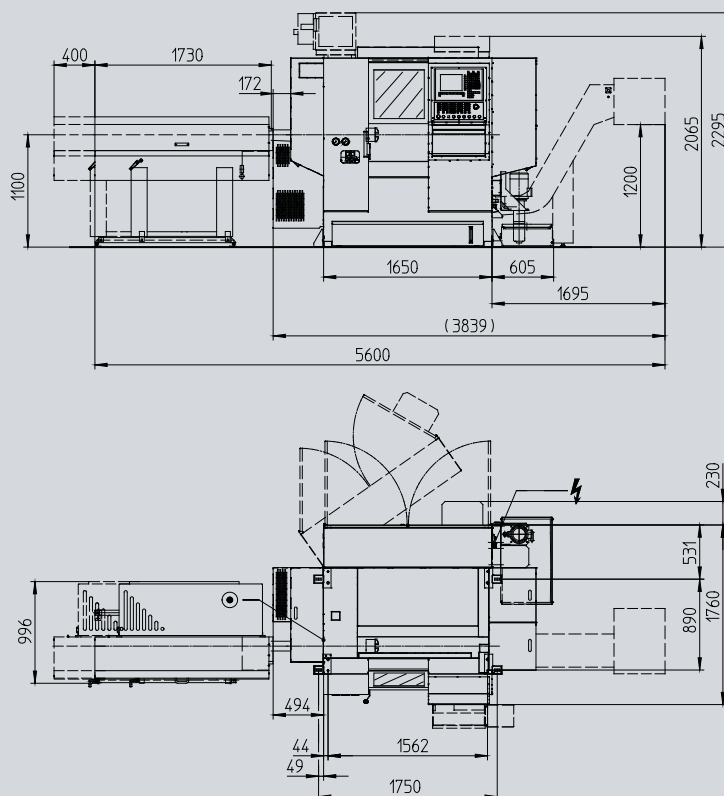

Work area EMCOTURN E45 with counter spindle

Work area and turret clearance EMCOTURN E45

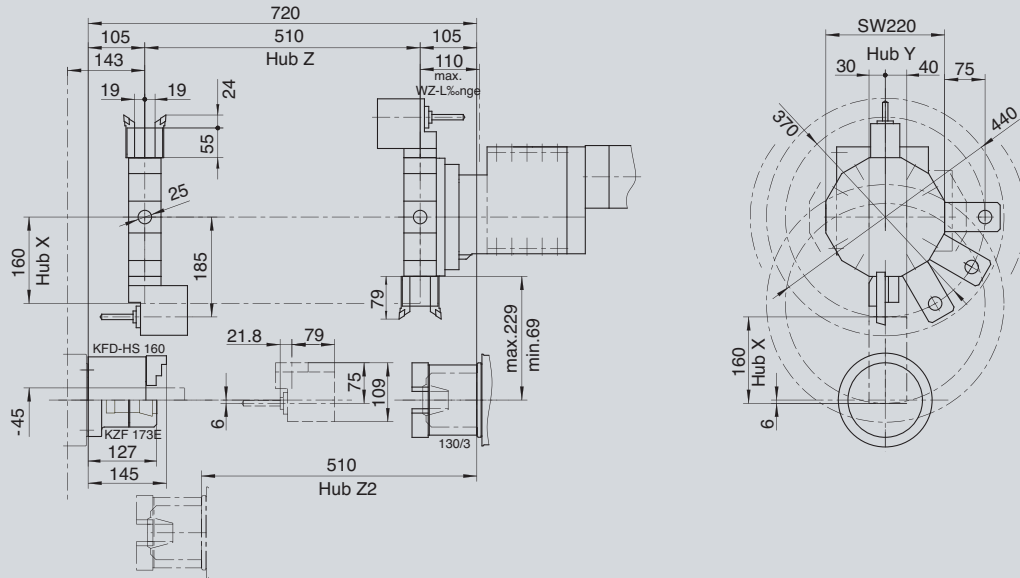

Performance diagram

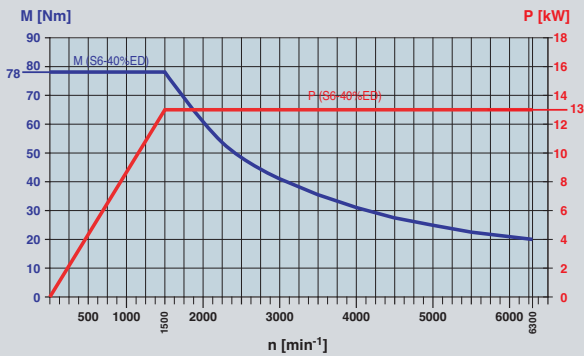

Motor characteristics for main spindle

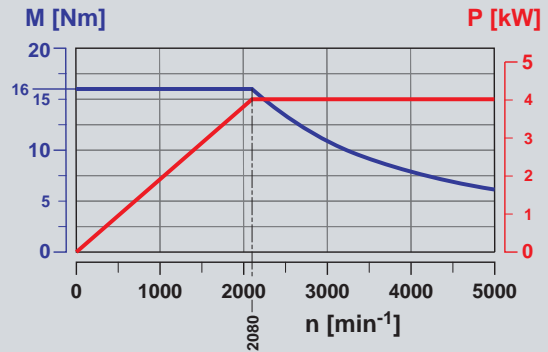

Motor characteristics for axial tool turret VDI30

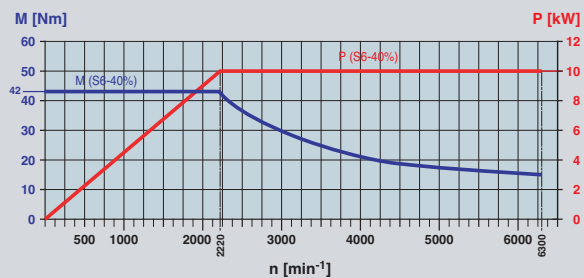

Motor characteristics for counter spindle

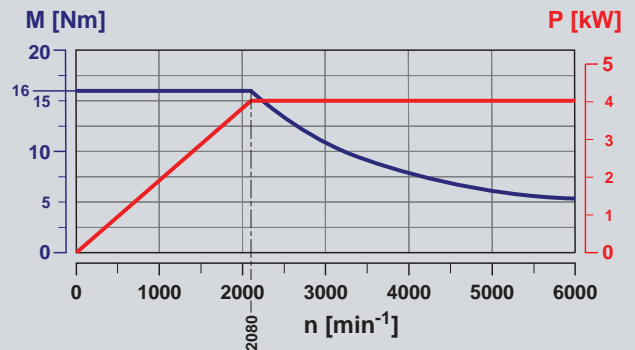

Motor characteristics for radial tool turret VDI25

EMCO swing loader. The integrated solution.

Tailor-made solutions. For preformed blanks and parts with a diameter larger than the spindle capacity, we offer an integrated swing loader for fully automated loading and part removal. This has been designed to form a harmonious single entity with the machine. The machine control system takes care of positioning. A short bar loader and a 3-meter bar loader are available from EMCO for workpieces from bar stock.

1 SWING LOADER

2 STROKE CONVEYOR BELT



Maximum output – Minimum space required.

The EMCO swing loader is a universal loading system for all types of pre-formed blanks. It can be customized individually to the customer's requirements using numerous gripper and handling systems. How we do it: we standardize the components but create a customized solution. The result: a custom-tailored machine for the same price as a standard unit.



Integrated Swing LOADER. The integrated EMCO Swing LOADER can pick-up the raw part from the feeding system and transfer it through the little door at the side into the machine. There the part is loaded into the chuck against a stop. If needed, the part also can be handled pre-oriented.



Finished parts. The finished parts are mostly unloaded with the parts-catcher on to a finished parts conveyor.

Customization:

A wide range of gripper and handling systems are available.



2-finger gripper with 180° rotary module for loading blanks fed in vertically



2-finger toggle lever gripper for loading shaft parts



Parallel grippers with 180° rotary module for loading shaft parts (1st and 2nd chucking)



Large storage capacity chain feeding system for loading preformed blanks with the correct orientation



Multiple infeed chutes for loading rotationally-symmetrical blanks. The length of the blanks determines the number of infeed chutes.



Chain feeding system with V-supports for preformed shaft parts of various shapes.

EMCOTURN E45

Technical Data

Work area

Swing over bed	430 mm (16.9")
Swing over cross slide	300 mm (11.8")
Distance between centers	670 mm (26.4")
Distance between spindle noses f. counter spindle version	720 mm (28.34")
Max. turning diameter with axial turret	220 mm (8.7")
with radial turret	300 mm (11.8")
Maximum part length	480 mm (18.9")
Maximum bar-stock diameter	Ø 45 (51) mm (1.77")

Travel

Travel in X / Z	160 / 510 mm (6.3" / 20.1")
Travel in Y	+40 / -30 mm (+1.6" / -1.2")

Spindle

Speed range	0 – 6300 (5000) rpm
Spindle torque	78 (100) Nm (57.5 ft/lbs)
Spindle nose DIN 55026	A2-5
Spindle bearing (inner diameter at front)	80 mm (3.1")
Spindle bore	53 mm (2.1")

Counter spindle

Speed range	0 – 6300 rpm
Spindle torque (Siemens / Fanuc)	42 / 43 Nm (31 / 31.7)
Spindle nose DIN 55026	KK 4
Spindle bearing (inner diameter at front)	70 mm (2.8")

C axis

Resolution	0.001°
Rapid motion speed	1000 rpm
Spindle indexing	0.01°

Automatic tailstock

Travel	510 mm (20.1")
Quill thrust	6000 N (1348.8 lbs)
Maximum travel speed	ca. 20 m/min (787.4 ipm)
Quill bore taper	MT 4

Drive Power

Main spindle	13 kW (17.4 hp)
Counter spindle (Siemens / Fanuc)	10 / 7,5 kW (13.4 / 10.1)

Tool turret axial / radial

Number of tool positions	12 / 12
Tool holding shaft in accordance with (DIN 69880)	30 / 25
Tool cross-section for square tools	20 x 20 / 16 x 16 mm (0.78 x 0.78 / 0.62 x 0.62")
Shank diameter for boring bars	Ø 32 / Ø 25 mm (1.25 / 0.98")
Turret indexing time	0.14 sec

Driven tools DIN 5480 axial / radial

Number of stations	6 / 12
Drive performance	4 / 4 kW (5.4 / 5.4 hp)
Maximum torque	16 / 16 Nm (11.8 / 11.8 ft/lbs)
Speed range	0 – 5000 / 0 – 6000 rpm

Feed drives

Rapid motion speed X / Y / Z	24 / 10 / 30 m/min (944.9 / 393.7 / 1181.1 ipm)
Feed force in the X / Y / axes	4000 / 4000 N (899.2 / 899.2 lbs)
Feed force in the Z axes	6000 N (1348.8 lbs)
Acceleration from 0 to rapid speed X / Z	6 / 8 m ²
Position variation Ps (according to VDI 3441) X / Y / Z	3 / 3 / 3 µm

Coolant system

Tank volume	250 liters (66 Gal)
Pump performance	0,57 (2,2) kW 0.77 (3 hp)
Pump power 3,5 bar / 1 bar	15 / 65 l/min
Pump power 9,5 bar / 5 bar (optional)	5 / 50 l/min

Power consumption

Connected load value	25 kVA
Air pressure required	6 bar

Dimensions

Height of center above floor	1100 mm (43.3")
Machine height	1960 mm (77.2")
Required space for machine (LxD)	2575 x 1760 mm (101.4 x 69.3")
Total weight of the machine Tailstock / Counter spindle	3300 / 4000 kg (7275 / 8818 lb)

Safety devices

CE compliant