

emcogroup

Designed for your profit

**[E[M]CONOMY
means:]**



The perfect combination of turning and milling know-how **HYPERTURN 200 Powermill**

Turn/Mill center for the complete machining
of large workpieces

HYPERTURN 200 Powermill

[Tool magazine]

- Optimal accessibility for tool assembly and inspection
- Up to 200 tool stations
- 3 additional stations for boring bars and long tools

[Main spindle]

- Double-gear motor for zero backlash C-axis
- Impressive performance: 84 kW - 6410 Nm - 1800 rpm
- Spindle nose A2-15"

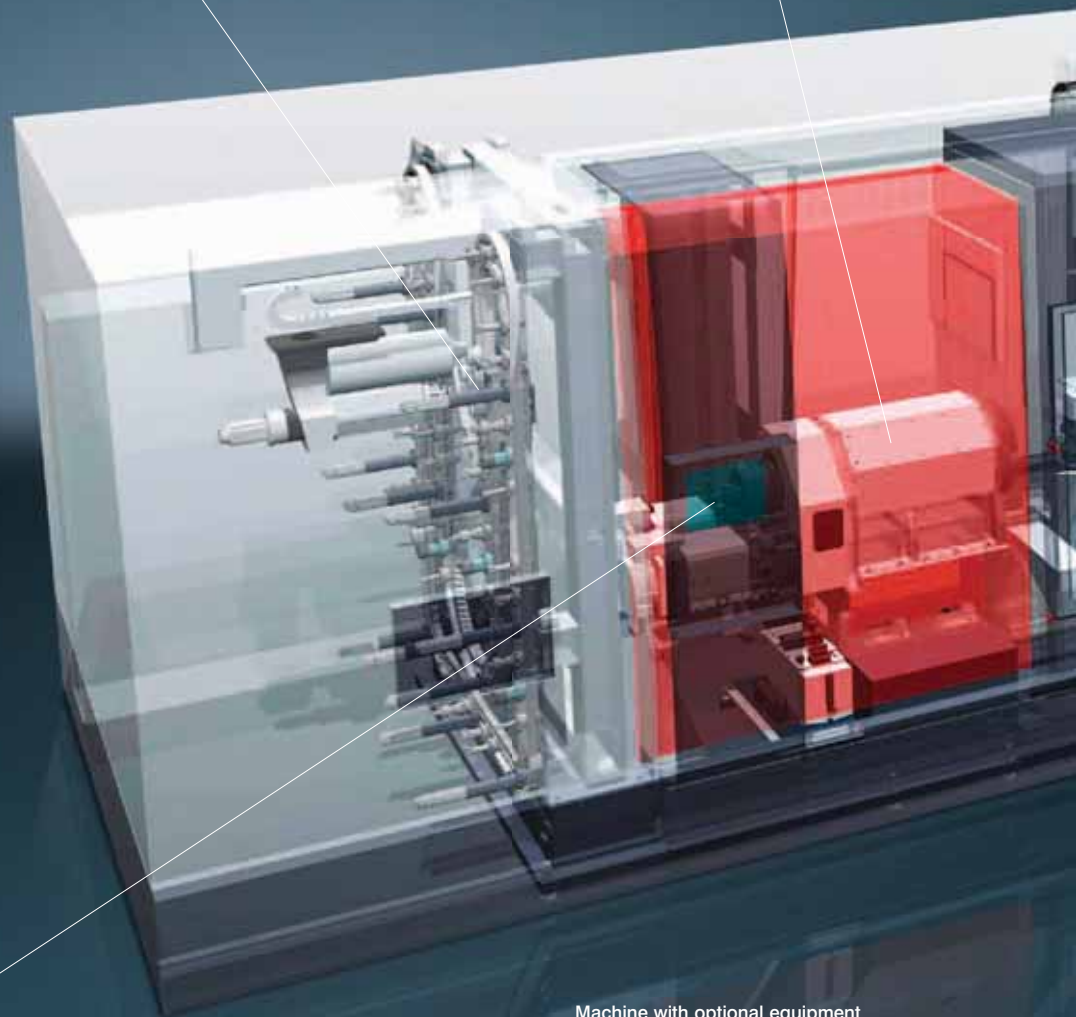

[Control]

- Sinumerik 840D sl with 19" color screen
- USB interface
- Swiveling and movable control panel

Machine with optional equipment

The Hyperturn 200 Powermill is the result of the successful merger of the EMCO Mecof know-how with the turning expertise of EMCO. High performance and productivity with only one clamping are demonstrated in the technical data – with a main spindle torque of 6410 Nm and a power of 84 kW, the new Hyperturn is optimally designed for all machining operations and does not have to shy away from the comparison. The rigid RAM structure, which is constructed as a Box-in-Box system, ensures maximum precision and stability.

[X-, Z-,Y-axes]

- Heidenhain glasscales in all axes
- High feed force
- Tailstock and steady-rest nc-controlled
- High and stable dimensioning in all axes

[Machine Design]

- Optimal use of space
- Innovative chip and coolant protection system
- Large work area
- Ergonomic accessibility

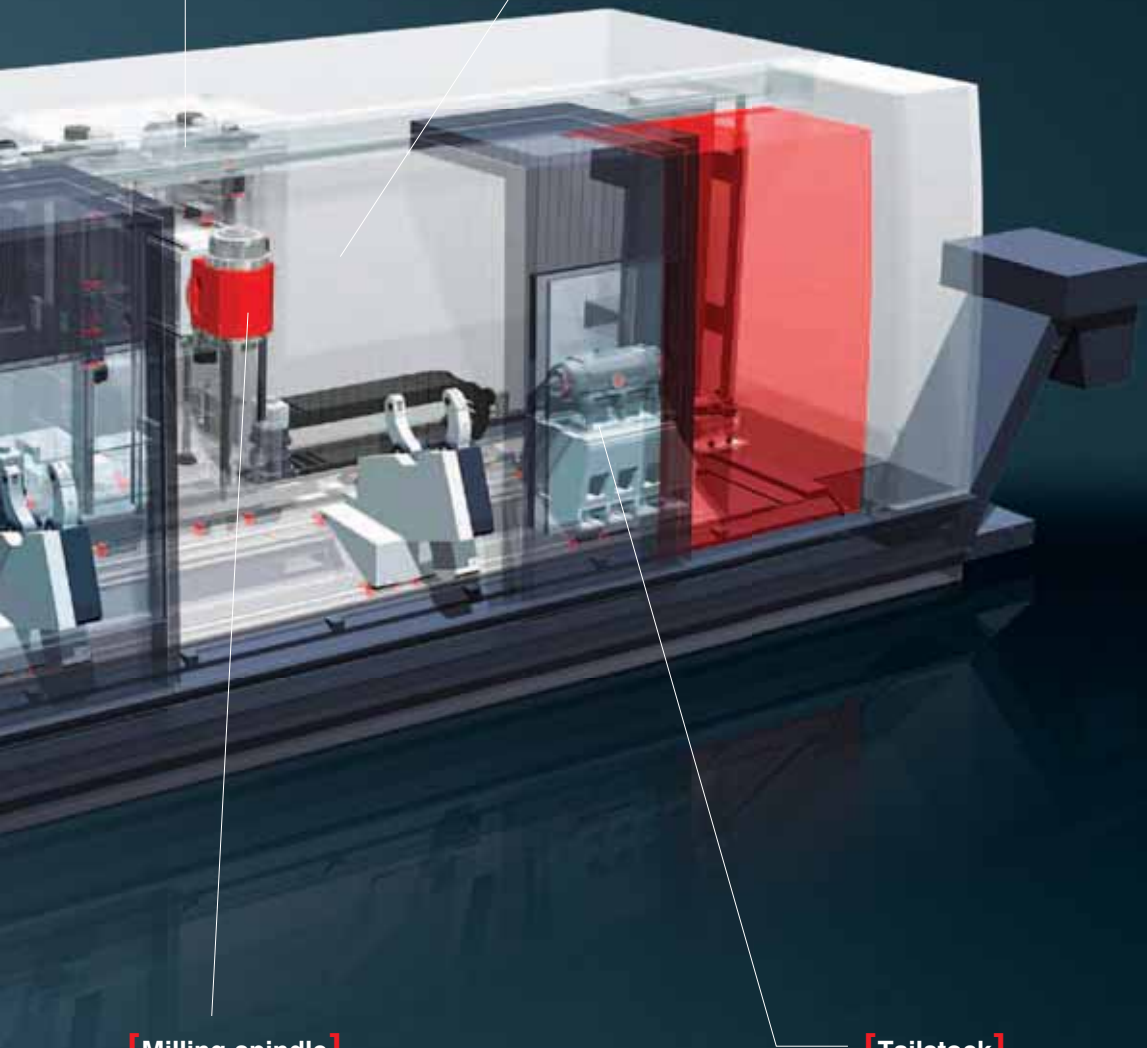

[Milling spindle]

- RAM system in Box in Box structure
- Choice of 2 milling spindles: both with a motor power of 80 kW, high torque (6500 rpm, 630 Nm) and high speed (10000 rpm, 340 Nm)
- Stable Y-axis: travel 600 mm

[Tailstock]

- Hydraulic quill
- Integrated bearings
- Eccentric quill settings for simplified cutting process
- NC-axis positioning
- 100% programmable and monitored

[Engineering]

Highlights

- Very large working space for the complete machining of large workpieces up to a turning diameter of 1000 mm with a maximum length of 6100 mm
- Moving column with box-in-box structure for maximum stability
- High-performance main spindle for heavy cutting at 84 kW and 6400 Nm
- Dynamic and precise B-axis with high torque and power
- Two versions of milling spindles with 6500 or 10000 rpm, with HSK-T 100 or PSC80 (Capto C8)
- Multitasking-control - Multi-technology SINUMERIK 840D sl
- Main spindle for high-performance processing with vibration-damped boring bars up to 1000 mm, including a special magazine (optional)
- Made in the Heart of Europe



Main spindle. For turning and milling operations, equipped with 84 kW and 6400 Nm torque. Sealing air, working area coolant and programmable clamping pressure are standard features on the Hyperturn 200. One or more programmable NC steady rest can assist the processing.

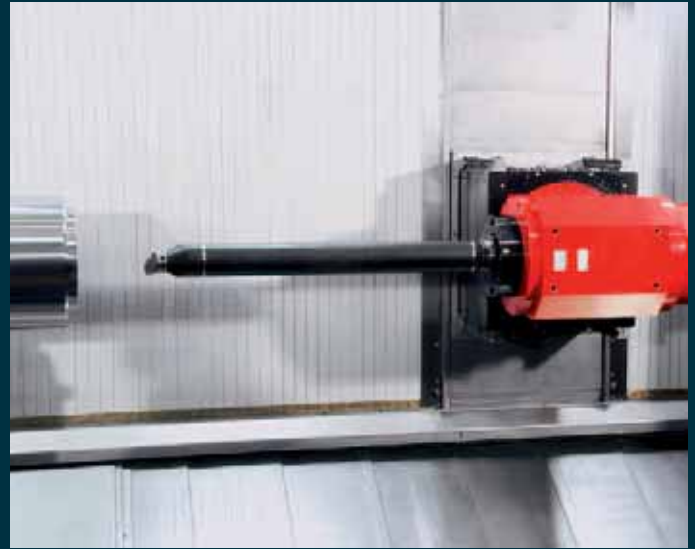

Turning operations. External or internal turning operations are possible with the stable spindle in 3° step. Optionally, the vibration-damped boring bar can be equipped up to a length of 1000 mm and with a 3-positions (stations) pick-up magazine.



Milling spindle. For stable, precise and flexible drilling and milling operations. Up to 80 kW and 630 Nm of torque and 10000 rpm. Sealing air, internal HP coolant with 40 bar and externally with 14 bar and a 1400 liter paper band filter system as standard (80 bar option). The B-axis can be used at any angle or with an indexed B-axis in 2.5° steps.



Tailstock. The tailstock is 100% programmable using the control. With the high-quality and precisely-dimensioned MK6 quill, all operations can be supported or extended with the counter spindle thanks to the machine modular construction.

Options

- Automatic tool presetting and workpiece measuring touch probe
- One or more NC steady rest
- 100 / 200 tool magazine positions
- High-speed milling spindle at 10000 rpm
- Boring bar pick-up system
- 5-axis simultaneous machining
- Coolant pressure 80 bar
- Virtual machine - collision monitoring
- EMCO remote/network service
- Tool load monitoring

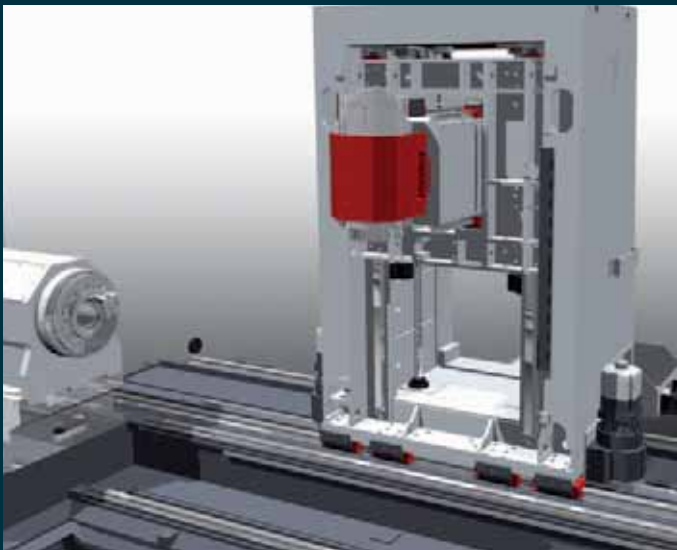

Machine Design. The merging of the milling expertise of EMCO MECOF with the turning skills of EMCO yields innovative results in performance and productivity.



Moving column. Is constructed like the EMCO MECOF machines with a „Box-in-Box“ RAM structure. Thus, optimum rigidity and stability are ensured and high accuracy machining is guaranteed. The B-axis is equipped with a torque motor and integrated into the Ram design.



XL magazine. Equipped with a 3-positions pick-up magazine, it includes tools up to a length of 1000 mm



Machining capabilities. With this performance profile and workspace dimensions the machine can produce large, complex workpieces with a maximum workpiece weight of 1500 kg in the chuck and up to 6000 kg between the chuck and tailstock.

Efficient modular solutions for the highest demanding requirements

Optionally, different standardized milling solutions are available: HSK or Capto (PSC), with water-cooled milling spindle with a max. 6500 or 10000 rpm. Optimal power and torque for every type of machining is achieved by the precise coordination of mechanics and control.

The Hyperturn 200 Powermill offers optimum conditions in terms of flexibility, set-up time reduction, stability and maximum productivity for the complete machining of large workpieces.

Power and torque diagram main spindle

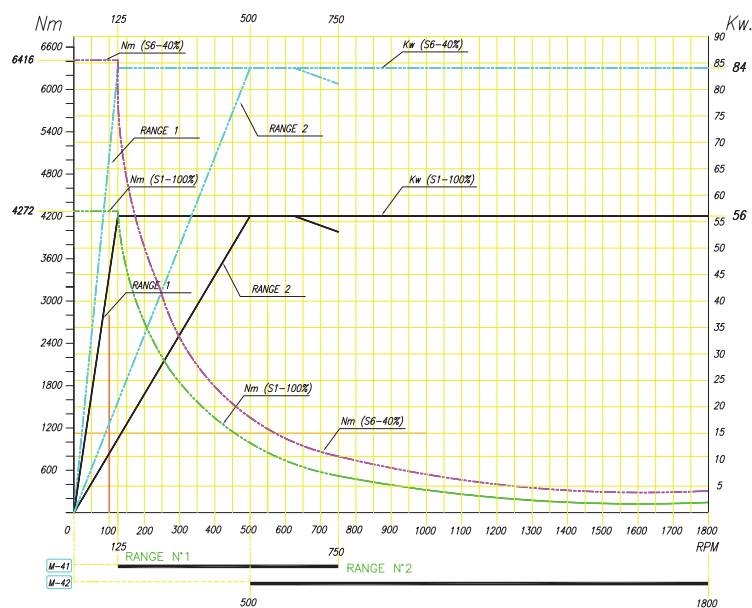

Main spindle. With performance data that make all machining possible without compromise. The EMCO spindle design has two servo motors that also act as C-axis. The motors operate in opposition, guaranteeing the balancing of the play and enabling the achievement of the power and torque as can be seen in the diagram above. The main spindle is also equipped with a special EMCO cooling system that optimizes the temperature stability and guarantees maximum precision with any length of machining.

Power and torque diagramm standard milling head

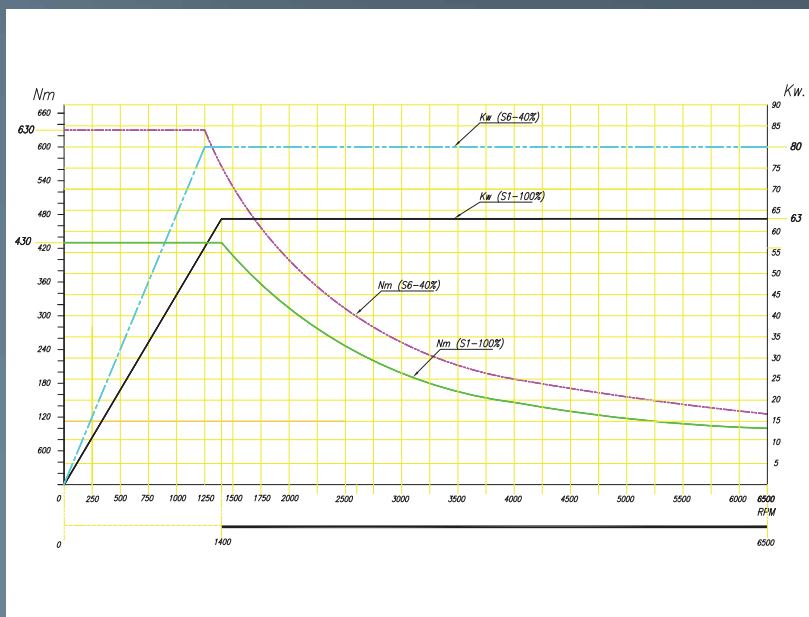

Milling spindle. Ready for use in the standard version with 6500 rpm for all turning, drilling and milling operations and technologies. The water-cooled ISM (integrated spindle motor) is available up to 80 kW and 630 Nm torque and with the HSK-T 100 or PSC80 (Capto C8).

Power and torque diagramm high speed milling head

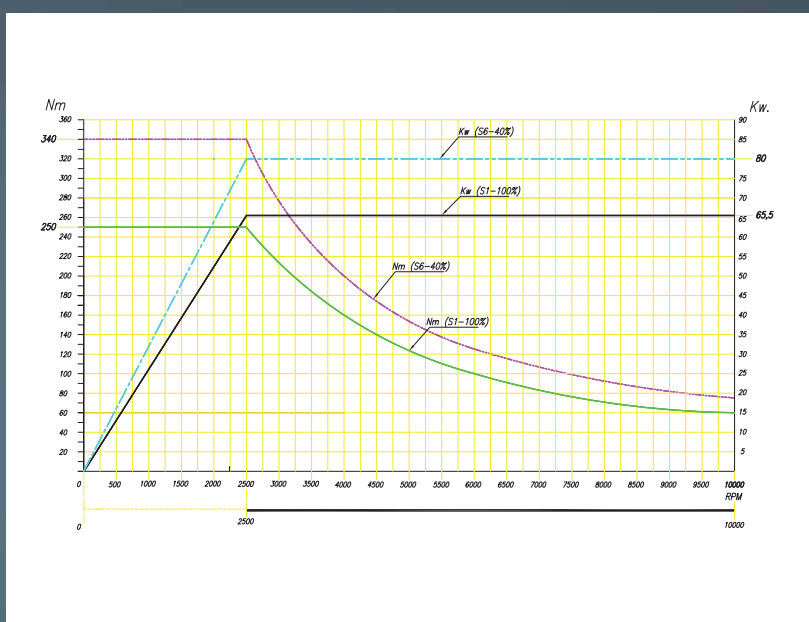

Milling spindle. Optional version with 10000 rpm. High speed for turning, drilling and milling operations, complex technologies usable for light alloys, aluminum, etc. The water-cooled ISM (integrated spindle motor) is available up to 80 kW and 340 Nm torque and with the HSK-T 100 or PSC80 (Capto C8).



ESPRIT™

The Right Choice

The Esprit CAM system offers high flexibility and process security, a comprehensive selection of machining cycles, maximum tool control, and cross-machine technology for your entire production facility.



[CAD]

Direct CAD data import

- AutoCAD (DWG)
- Parasolid®
- Solid Edge®
- Solid Works®
- ACIS® (SAT)
- Optional interfaces: CATIA®, Pro/ENGINEER®, STEP, STL,...

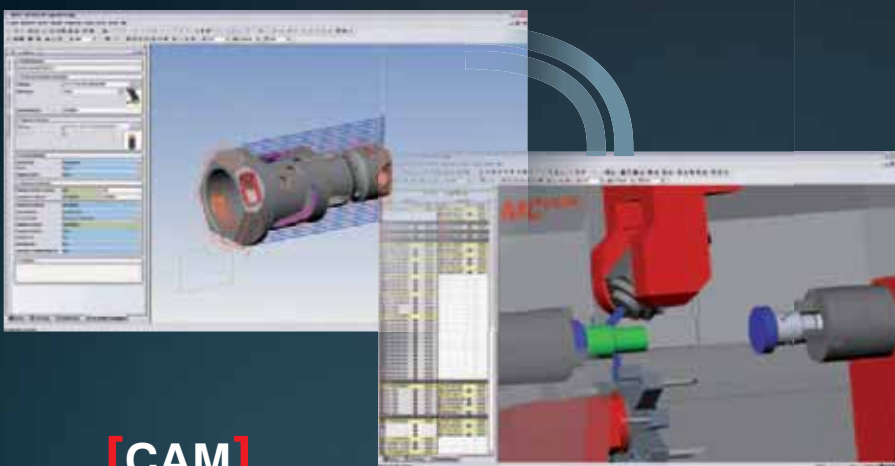

[CAM]

- 2-22 axis turning
- 2-5 axis milling
- Multi-tasking of turning and milling
- 3D machine space simulation
- Certified post-processors

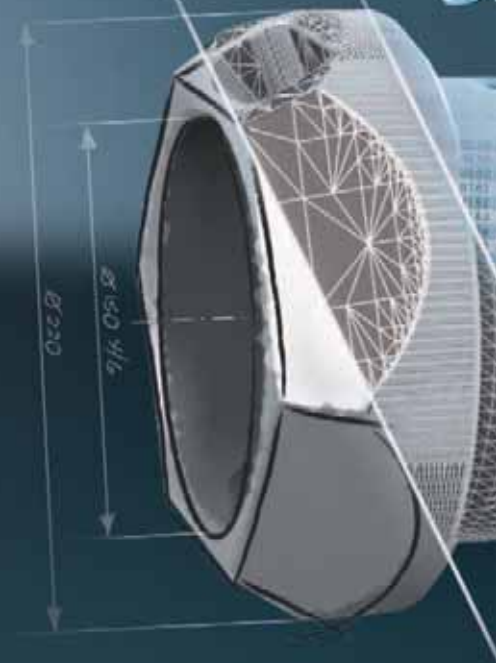

[CAD]

emcoCPS | Pilot

The Virtual Machine

A 1:1 mapping of the real machine for defining and testing processes, optimizing machining sequences, and training new operators.

[Process chain]

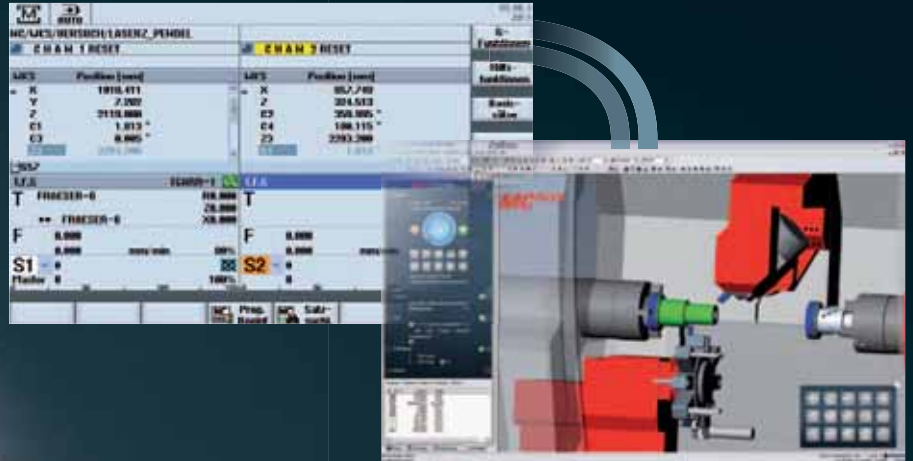

[CPS]

- 1:1 simulation with collision detection
- Direct connection to CAM ESPRIT
- Process optimization
- Reverse simulation of existing NC codes
- Reduction in scrap rates
- Training on the virtual machine
- Simulation of loading systems (e.g. EMCO gantry loader)

[CAM] [CPS] [Production]



[Production]

- Reduction in set-up costs
- Reduction in downtimes
- Reduction in repair costs

OPTIMUM MACHINE UTILIZATION

SINUMERIK 840D sl

Open, powerful, flexible

The Sinumerik 840D sl with Operate user interface is ergonomically located at EMCO on the left of the work area and can be swivelled approx. 120° and - with the Hyperturn 200 - also be moved. Shopturn dialog programming, RJ45 and a 230 volt outlet on the side are included in the standard version as well as a robust OP19" touchscreen for industrial use.



Shopturn-Shopmill / Machining cycles: The machine programming can be chosen completely freely from ISO to Shopturn. Complex workpieces require efficient production methods and innovative CNC solutions. The SINUMERIK 840D sl CNC equipment supports multi-technology equipment in the machining of workpieces in one setup and offers innovative functionality for this - even alternating between different technologies.

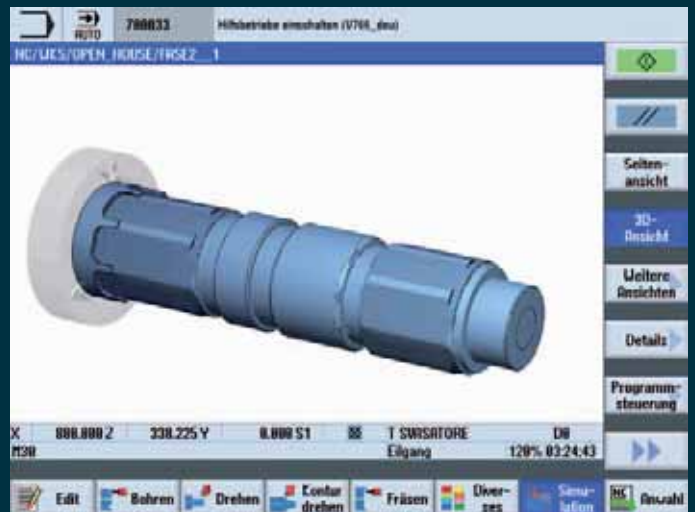

Machining simulation: 3D simulation, simultaneous display during the turning and milling - with representation of detail and workpiece cutting. This achieves a significantly higher efficiency in production and all information is available on the machine.



Tool management: Simple and open operation through an integrated management tool for all tool types and data.

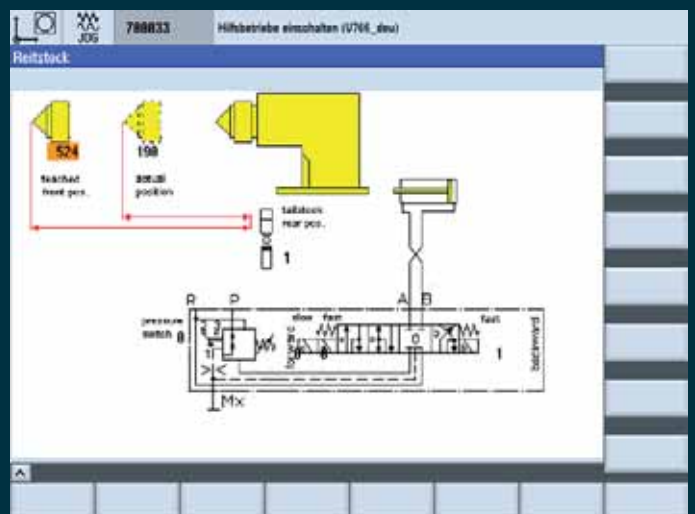

EMCO Diagnostics: EMCO Diagnostics for rapid, easy analysis of the whole machine (for example: tailstock hydraulic scheme and quill position monitoring).

[Installation plans]

HYPERTURN 200 Powermill installation plan

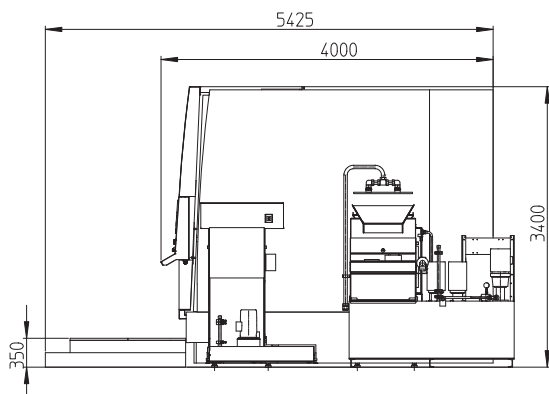
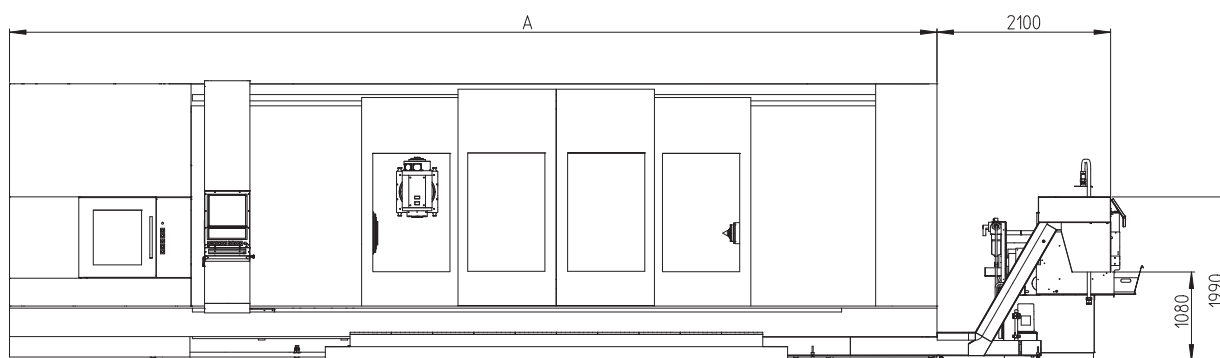
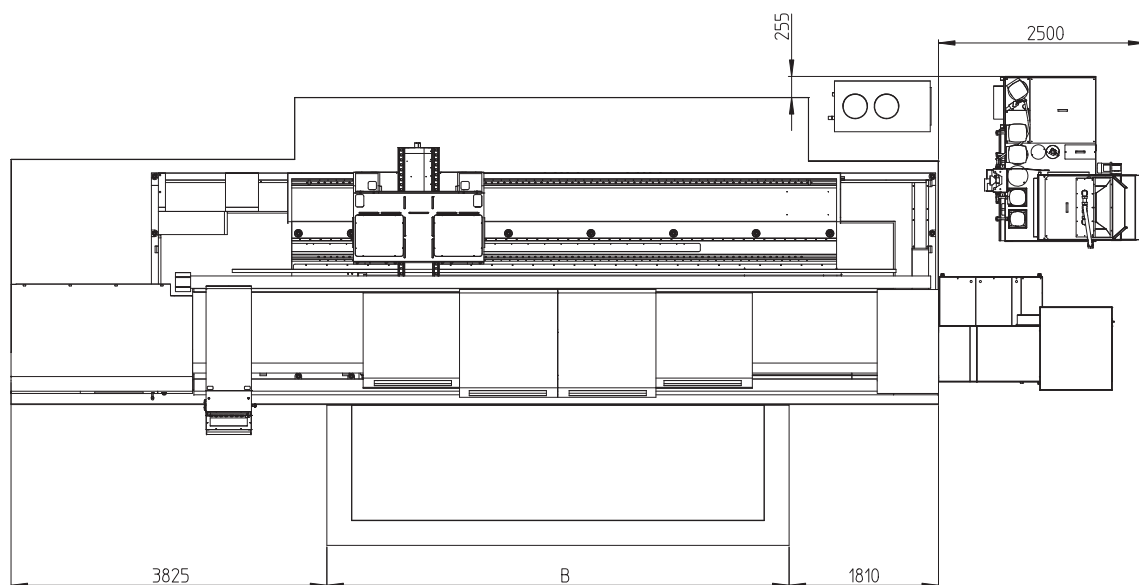

	MACHINE LENGTH			
	3000	4000	5000	6000
A	10235	11235	12235	13235
B	4600	5600	6600	7600

Quality components



[Clamping cylinder, chuck, steady rest]

A hydraulically actuated clamping cylinder and clamping chucks guarantee accurate and secure clamping of the workpieces. The stroke control is realized by means of programmable sensors. The time-consuming adjustment of non-contact limit switches is eliminated.



www.smwautoblok.de

[Tool magazine]

The extensive machining capabilities require a wide variety of tools. Up to 200 tool positions, lengths up to 600 mm and tool weights of up to 30 kg are no problem for the fast tool changer with double gripper.



www.cftautomation.it

[Machine beds / Slides]

In the alignment of the components, we place the emphasis on stability, good damping behavior, and a thermo-neutral construction. The high stability is achieved by a short power flow, thermal stability by symmetry and the damping by the choice of materials and interfaces.

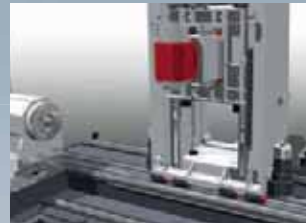

www.emco-world.com
www.combasrl.com

[Milling spindle / B-axis]

The new ISM milling spindle and B-axis torque motor unit from Weiss Spindeltechnologie GmbH in stands out in particular for its high precision, as well as an extremely high torque and represents today's state of the art

The backlash-free milling drive allows not only turning, milling and drilling but also thread cutting without compensation chucks, gear hobbing as well as various special technologies. In combination with the CNC Sinumerik Sinamics control, the commissioning and complete monitoring of the spindle in the machine is significantly easier.



www.weissgmbh.com

[Spindle tooling]

The design and manufacture of spindle tooling is one of the core competencies of EMCO. In the engineering the focus is on precision, robustness, high rigidity, precision concentricity and a longer service life.



www.emco-world.com
www.algra.it

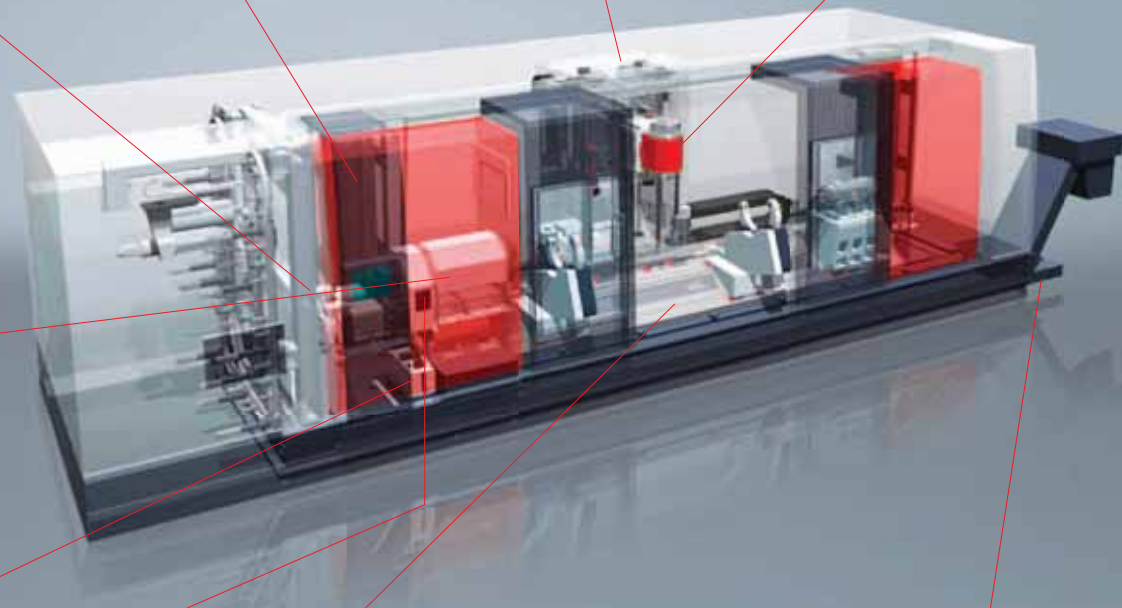

[Hydraulic system]

Compact size, quiet operation and high energy efficiency are among the advantages of the hydraulic aggregates used by EMCO. A tracking pressure switch saves time-consuming, manual adjustment of the pressures.



www.hawe.de

[Ball screws, roller guides, rack drives, glass scale]

High-precision and large-sized guide rails, ball screws and rack drives with optimal preloading provide the basis for the machining of precision parts. High feed force and heavy and accurate machining can be performed easily.



www.boschrexroth.com
www.redex-andantex.com

[Chip conveyor, paper tape filter, coolant pump]

Hinged belt conveyors can be used flexibly and provide for the safe removal of the chips. An overload coupling with monitoring prevents damage on improper use, the 1400 l paper tape filter specifically for difficult to machine materials require, in addition to a high pressure, a very high coolant flow rate. Low-maintenance submersible pumps for pressures up to 80 bar and flow rates up to 25 l/min offer optimal conditions for the machining and ensure a reliable chip transport.



www.bmf.de

Work area

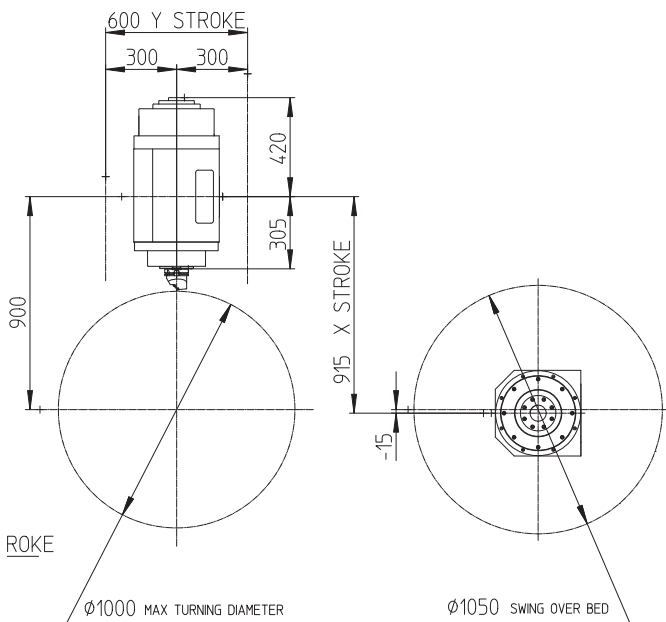
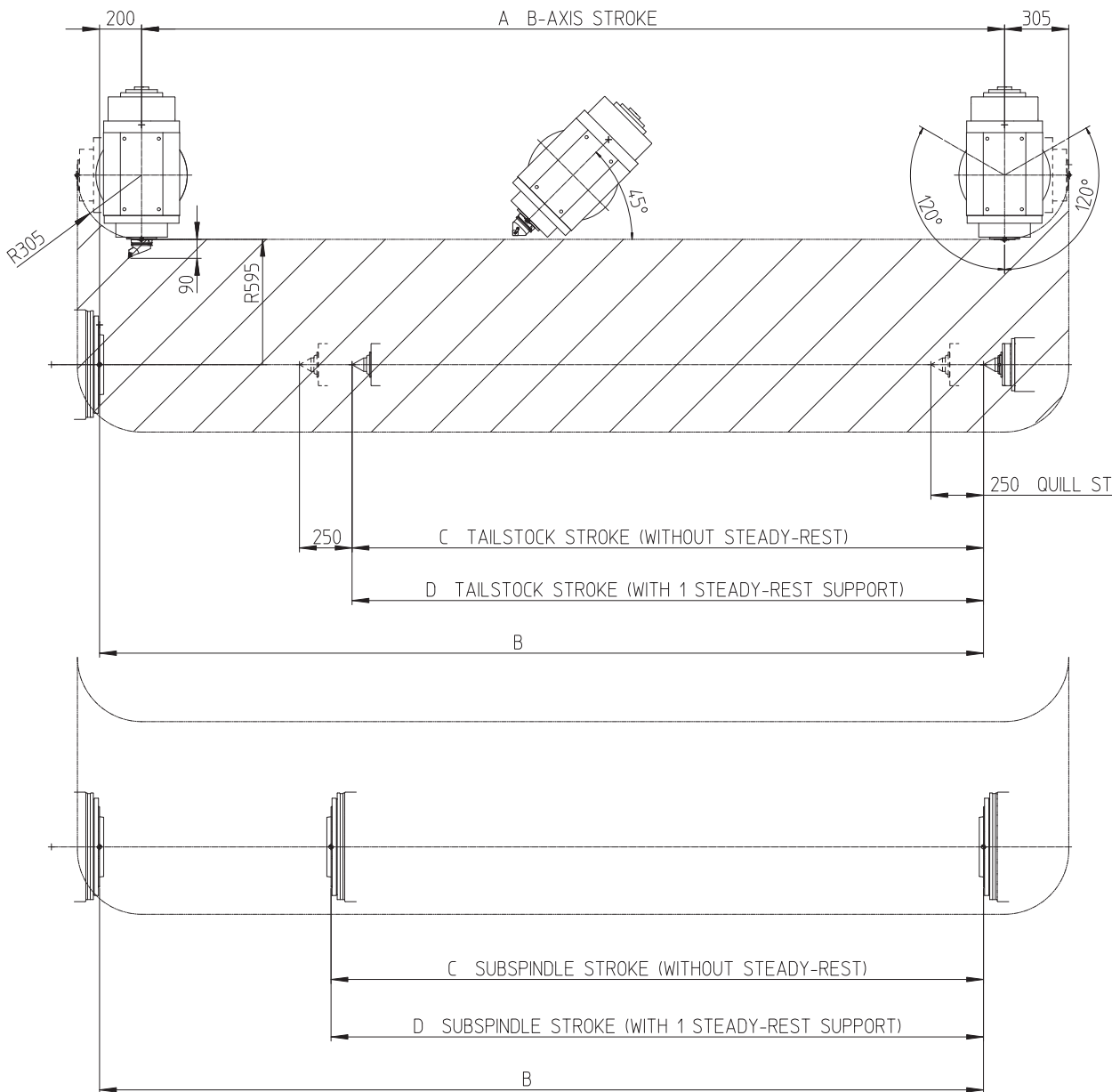

		MACHINE LENGTH			
		3000	4000	5000	6000
A		3100	4100	5100	6100
B		3200	4200	5200	6200
C		3000	4000	/	/
D		2100	3100	4100	5100

[Technical data]



Designed for your profit

EMCO HYPERTURN 200 Powermill

Workspace	
Swing diameter over the bed	1050 mm
Max. turning diameter	1000 mm
Distance between spindle and center (MK 6)	3200 / 4200 / 5200 / 6200 mm
Stroke X axis	915 mm
Stroke Z axis	3100 / 4100 / 5100 / 6100 mm
Stroke Y axis	+/- 300 mm
Main spindle and counter spindle (optional)	
Spindle connection (DIN 55026)	A2-15"
Power chuck diameter	500 / 630 / 800 mm
Max. spindle speed (with gear)	1800 rpm
Max. power	84 kW
Max. torque	6410 Nm
Max. weight including feed	1500 kg
Max. weight between the centers including feed	6000 kg
Tailstock with quill	
Travel without steady rest	3000 / 4000 / 5000 / 6000 mm
Quill travel	250 mm
Quill diameter	200 mm
Max. thrust	40000 N
Tailstock travel speed	15 m/min
Bore tape dimension (intergrate bearing)	MT 6
X, Z, Y-axis	
Rapid traverse speed X/Y/Z	30 / 30 / 30 m/min
Feed force X	30000 N
Feed force Z	30000 N
Feed force Y	20000 N
Diameter X-axis ball screw x pitch (2 time)	63 x 20 mm
C-axis of main spindle	
Angular resolution	0,001°
Max. torque	5000 Nm
Spindle brake - holding torque	6000 Nm
Max. speed	50 rpm

Milling spindle / B-axis	
Tool system	HSK-T 100 / PSC80 (Capto C8)
Max. drive power	80 kW
Max. spindle-speed (opt.)	6500 (10.000) rpm
Max. torque (opt.)	630 (340) Nm
B-axis stroke	240°
Max. torque with index B-axis	15000 Nm
Max. torque with interpolation B-axis	2130 Nm
Smallest index	2,5°
Smallest increment B-axis	0,001°
Tool magazine	
Tool magazine positions	50 – 100 – 200
Max. tool length	600 mm (opt. 3 x 1000 mm)
Max. tool diameter	120 mm
Max. turning tool weight	25 kg
Coolant system	
Coolant pressure	40 / 14 bar
Flow rate at 20 bar	30 l
Filter system	40 Micron
Coolant tank capacity	1400 l
Power consumption	
Power rating	125 kVA
Compressed air connection	6 bar
Dimensions	
Height above floor	1550 mm
Total length with chip conveyor and cooling system	12400 / 13400 mm
Height	3400 mm
Width / with control panel	4000 mm
Weight (depending on the type and accessories)	40000 – 54000 kg
Transport Dimensions L x H x W	10400 / 11400 / 12400 / 13400 x 3400 x 3100 mm



Certificato di sistema di gestione
Qualità N° 50 100 12715

EN5464 - 07/16 - Technical modifications reserved. Errors and omissions excepted.

www.emco-world.com